

OPERATOR'S MANUAL

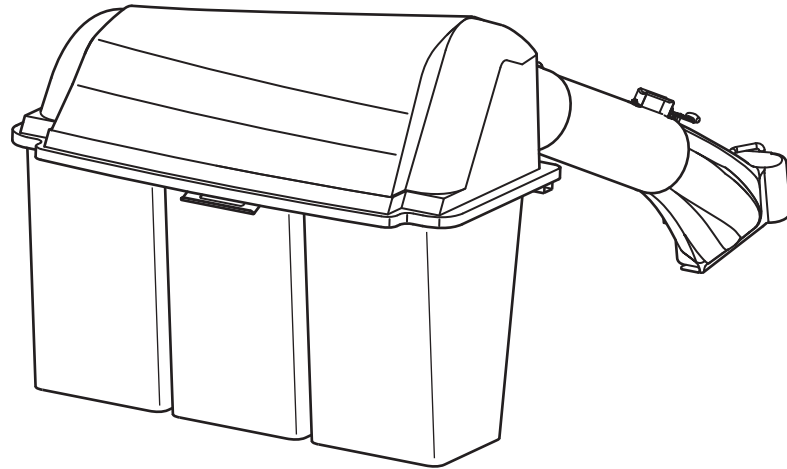

Turboless Triple Catcher

Turboless Triple Catcher

Mfg. No.	Description
1695354	44" & 50" Turboless Triple Catcher

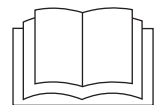

CAUTION: Read and follow all instructions.

Manual Part No. 1734740

Revision 01

Rev. Date 05/2007

TP 100-4527-01-AT-SMAN

SAVE THESE INSTRUCTIONS

READ THE MANUAL

The operator's manual contains important safety information you need to be aware of **BEFORE** you operate your unit as well as **DURING** operation.

Safe operating techniques, an explanation of the product's features and controls, and maintenance information is included to help you get the most out of your equipment investment.

Failure to obey the safety rules could result in loss of control of the unit, sever personal injury or death to you, or bystanders, or damage to property or equipment.

Safety Icons

The alert symbol  is used to identify safety information about hazards that can result in personal injury. A signal word (DANGER, WARNING, or CAUTION) is used with the alert symbol to indicate the likelihood and the potential severity of the injury. In addition, a hazard icon may be used to represent the type of hazard. An explanation of hazard levels and icons are as follows:

DANGER

This indicates a hazard which, if not avoided, **will result in serial injury or death.**

WARNING

This indicates a hazard which, if not avoided, **could result in serial injury or death.**

CAUTION

This indicates a hazard which, if not avoided, **might result in minor or moderate injury.**





Hazard Symbols and Meanings			
Safety Icon	Hazard	Safety Icon	Hazard
	Alert		Read the Manual
	Thrown Objects		Remove Key Before Servicing
	Machine Rollover		Rotating Parts – Do Not Touch

Table of Contents

Operator Safety	2
Operator Safety	2
Safety Decals	2
Mowing with the Catcher	3
Before Operation	3
After Operation	3
Storing the Catcher	3
Assembly	5
Install Mounting Plates & Spacers (Broadmoor/1600/2600/LT Series)	5
Install Mounting Spacers (Conquest/1700/2700/YT & Prestige/1800/2800/GT Series)	5
Remove Blowout Baffle	6
Install Baffles	7
Install Components	8
Install Bag and Cover Support	10
Install Hitch and Upright Support Assembly	10
Install Cover Assembly	10
Install Collector Bags	11
Install Lower Discharge Chute	11
Install Upper Tube to Cover	12
Install Middle Tube	12
Normal Removal & Installation	14
Installation	14
Removal	15

GENERAL WARNINGS

- Know the unit's controls and how to stop quickly. READ THE OPERATOR'S MANUALS.
- Read and obey all safety decals.
- Only allow responsible adults, who are familiar with the instructions, to operate the unit.
- Disengage the PTO. Shut off the engine and wait for all moving parts to stop before attaching, adjusting, or disconnecting any part of the collection system.
- Check the collection system to make sure it is bolted tightly to the unit.
- DO NOT operate the unit without either the entire grass catcher or the deflector in place.
- Turn off the PTO to disengage the blades when not mowing.
- DO NOT mow in reverse unless absolutely necessary. Always look down and behind before and while travelling in reverse.
- DO NOT turn sharply when travelling alongside a building or any object. Slow down before turning.
- DO NOT carry passengers.
- When collection system is removed from the mower deck, the deflector must be properly installed.
- Collector bags are subject to deterioration and wear during normal use. Inspect the bag periodically for tears, holes, or weak spots and replace with a new bag that meets manufacturer's durability standards.
- If the mower stalls or the collector chute plugs:
 1. Disengage the PTO;
 2. Stop the engine and remove the key;
 3. Set the parking brake, and wait for all moving parts to stop.
 4. Remove the foreign object or clear the chute with a piece of wood before restarting the engine. **NEVER place hands into COLLECTOR OR MOWER housing to clear jammed objects. Blower OR MOWER may rotate when object is removed.**
- For added stability and to prevent tipping or loss of control:
 - a. Use reduced speed on uneven ground and when turning corners.
 - b. Reduce loads on hillsides. It is recommended that the collection system be kept only half full when negotiating any slopes. Start mowing on slopes when the collection system is empty.
 - c. Mow up and down the face of slopes; never across the face of any slope.
- **Never operate on slopes greater than 17.6° (10°).**

SAFETY DECALS

This unit has been designed and manufactured to provide you with the safety and reliability you would expect from an industry leader in outdoor power equipment manufacturing.

Although reading this manual and the safety instructions it contains will provide you with the necessary basic knowledge to operate this equipment safely and effectively, we have placed several safety labels on the unit to remind you of this important information while you are operating your unit.

All DANGER, WARNING, CAUTION and instructional messages on your rider, attachments and mower should be carefully read and obeyed. Personal bodily injury can result when these instructions are not followed. The information is for your safety and it is important! The safety decals below are on your product.

If any decals are lost or damaged, replace them at once. See your local dealer for replacements.

These labels are easily applied and will act as a constant visual reminder to you, and others who may use the equipment, to follow the safety instructions necessary for safe, effective operation.

Attachment Decal



Decal - WARNING Thrown Objects Hazard
Part Number 1732819

Read and obey all operation and warning decals.

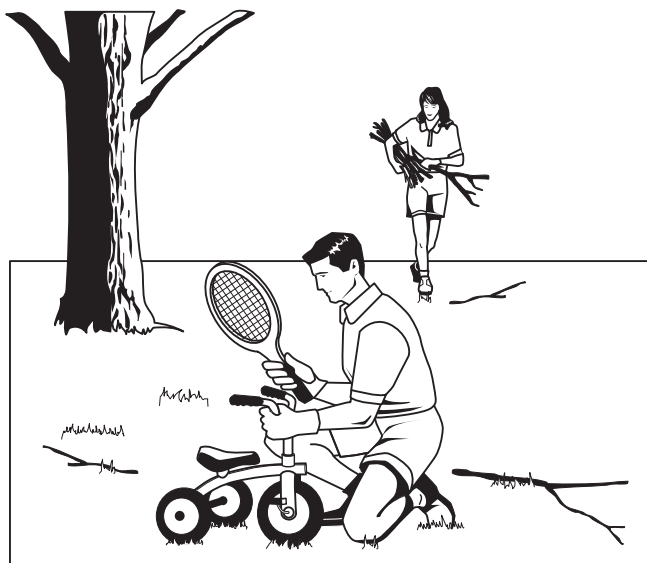

Mowing with the Catcher

Always operate with throttle at full speed when mowing.

Grass should be cut often, and not too short. If grass is too long or lush it may be necessary to keep ground speed to a minimum or to cut only half the width of the mower to prevent clogging. If grass is long, operate with mower in high cutting position for first pass, cutting again in a lower position on a second pass.

Do not open the cover with mower engaged.

If a large amount of cut grass is spilling out from under deck, the tube may be plugged or the bags may be full—discontinue mowing, stop the unit, disengage the PTO, shut off the engine and then empty the catcher or clear the tube.

⚠ WARNING

ALWAYS shut off the tractor. Disengage the PTO, and allow all moving parts to stop **BEFORE** disconnecting or clearing tube, or emptying catcher.

Before leaving the operator's position for any reason, engage the parking brake, disengage the PTO, stop the engine and remove the key.

To reduce fire hazard, keep the engine, rider and mower free of grass, leaves and excess grease. Do not stop or park rider over dry leaves, grass or combustible materials.

Before Operation

Clear the lawn of all sticks, stones, wire and other debris which may be caught or thrown by the mower blades.

Check grass condition. If wet, wait until later in the day. If grass is wet, the grass catcher is likely to become plugged.

For efficient bagging, air circulation under the mower deck, through the chute and into the bag is very important.

For this reason, **BEFORE YOU BEGIN MOWING** you should make certain the underside of the mower and the underside of the catcher lid are free from grass and debris.

Make sure that there is a snug fit between mower deck, blower housing, tubes, and grass catcher cover.

⚠ CAUTION

Before you begin operating the unit be certain you have read all of the safety and operational information of this instruction sheet, as well as the Operator's Manual for the tractor and any other attachments.

Never operate on slopes greater than 17.6% (10°).

After Operation

Remove any debris from the the screen on the underside of the lid.

The blower housing and tube should be removed for cleaning.

Inspect the grass bags for wear or damage. Make sure that there is a snug fit between mower deck, blower housing, tubes, and grass catcher cover.

Storing The Grass Catcher

Clean the grass catcher thoroughly using a mild detergent (other products may damage the tube). Remove any debris from the screen on the underside of the lid.

If paint has been scratched on metal parts, touch up with paint, or apply a thin film of oil to prevent corrosion.

Store in a dry area. Dry thoroughly before storing for a long period of time. Always store away from moisture.

⚠ CAUTION

Do not leave grass in bagger containers. Empty containers after each use and before storing. Failure to do so may result in spontaneous combustion which could develop into a fire.

Assembly

INSTALL MOUNTING PLATES - BROADMOOR / 1600 / 2600 / LT SERIES

Install Plates & Spacers

1. Mount the side brackets (C, Figure 1) to both sides of the frame using the holes shown. Secure with one 3/8-16 x 1 capscrew (D), 3/8 lockwasher (B), and 3/8-16 nut (A) per side.
2. Install the rear spacers (C, Figure 2). Secure with two 1/2-13 x 2-1/2 capscrews (E), washers (D), spacers (C), and 1/2-13 nylock nuts (A) per side.

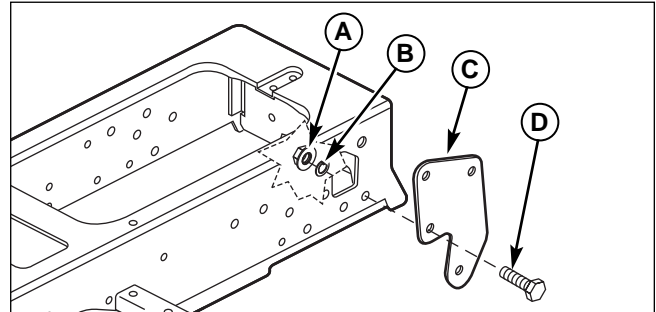

Figure 1. Install Side Brackets

- A. Nut, 3/8-16**
- B. Lockwasher, 3/8**
- C. Side Bracket**
- D. Capscrew, 3/8-16 x 1**

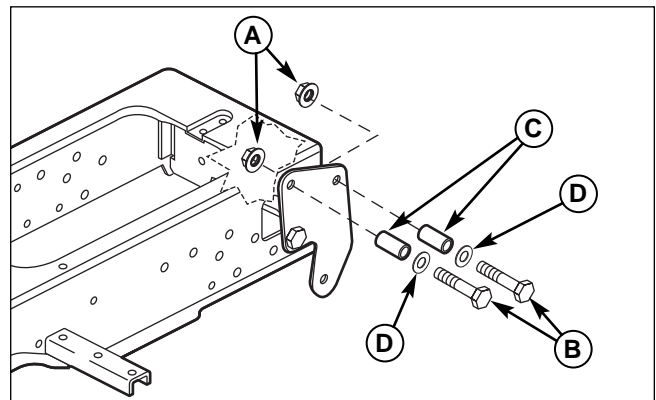

Figure 2. Install Rear Spacers

- A. Nylock Nuts, 1/2-13**
- B. Capscrew, 1/2-13 x 2-1/2**
- C. Spacers**
- D. Washers, 1/2**

INSTALL MOUNTING SPACERS - CONQUEST / 1700 / 2700 / YT & PRESTIGE / 1800 / 2800 / GT SERIES

Install Spacers

1. Install the rear spacers (C, Figure 3). Secure with two 1/2-13 x 2-1/2 capscrews (E), washers (D), spacers (C), and 1/2-13 nylock nuts (A) per side.

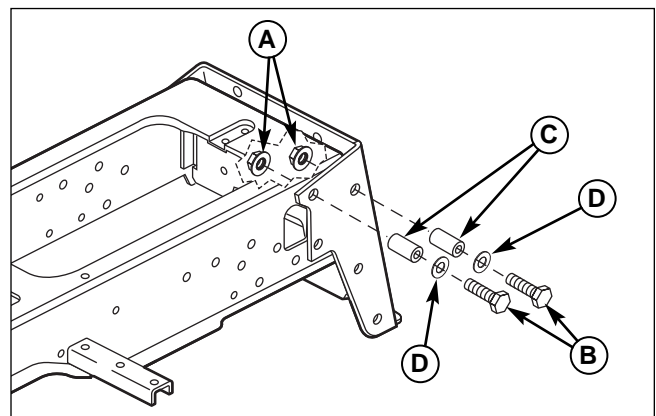

Figure 3. Install Rear Spacers

- A. Nylock Nuts, 1/2-13**
- B. Capscrews, 1/2-13 x 2-1/2**
- C. Spacers**
- D. Washers, 1/2**

Remove Blowout Baffle

1. Remove and discard short blowout baffle (C, Figure 4), carriage bolts (B) and locknuts (D) from mower deck (A).

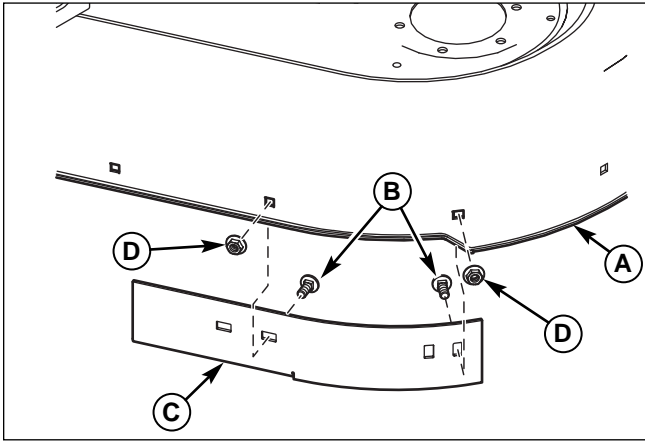

Figure 4. Baffle Removal

- A. Mower Deck
- B. Carriage Bolts, 5/16-18 x 3/4
- C. Blowout Baffle, Short
- D. Nuts, Whizlock, 5/16-18 x 3/4

Install Baffles

1. Determine which baffle to use. See Figure 5 Chart.
2. Lift side discharge chute (H, Figure 6).
3. Insert baffle (F) through discharge opening and position baffle into place.
4. Tighten carriage bolts (A) and nuts (E) on baffle (F).
5. Tighten carriage bolt (B) and nut (E) on baffle (F).
6. Position baffle (G) into place.
7. Tighten carriage bolts (C) and nuts (E) on baffle (G).
8. Tighten carriage bolts (D) and nuts (E) on baffle (G).

	44" Mower Deck	50" Mower Deck
"A"	RH side 26-1/4" long	RH side 29-3/4" long
"B"	LH side 24-7/8" long	LH side 27-3/4" long

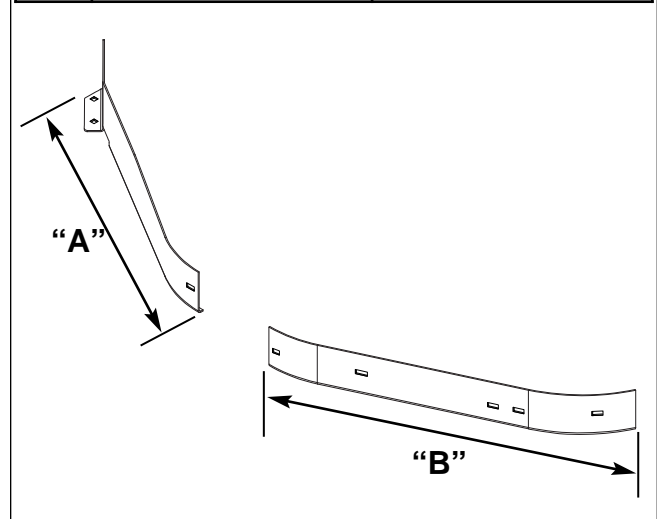

Figure 5. Baffle Chart

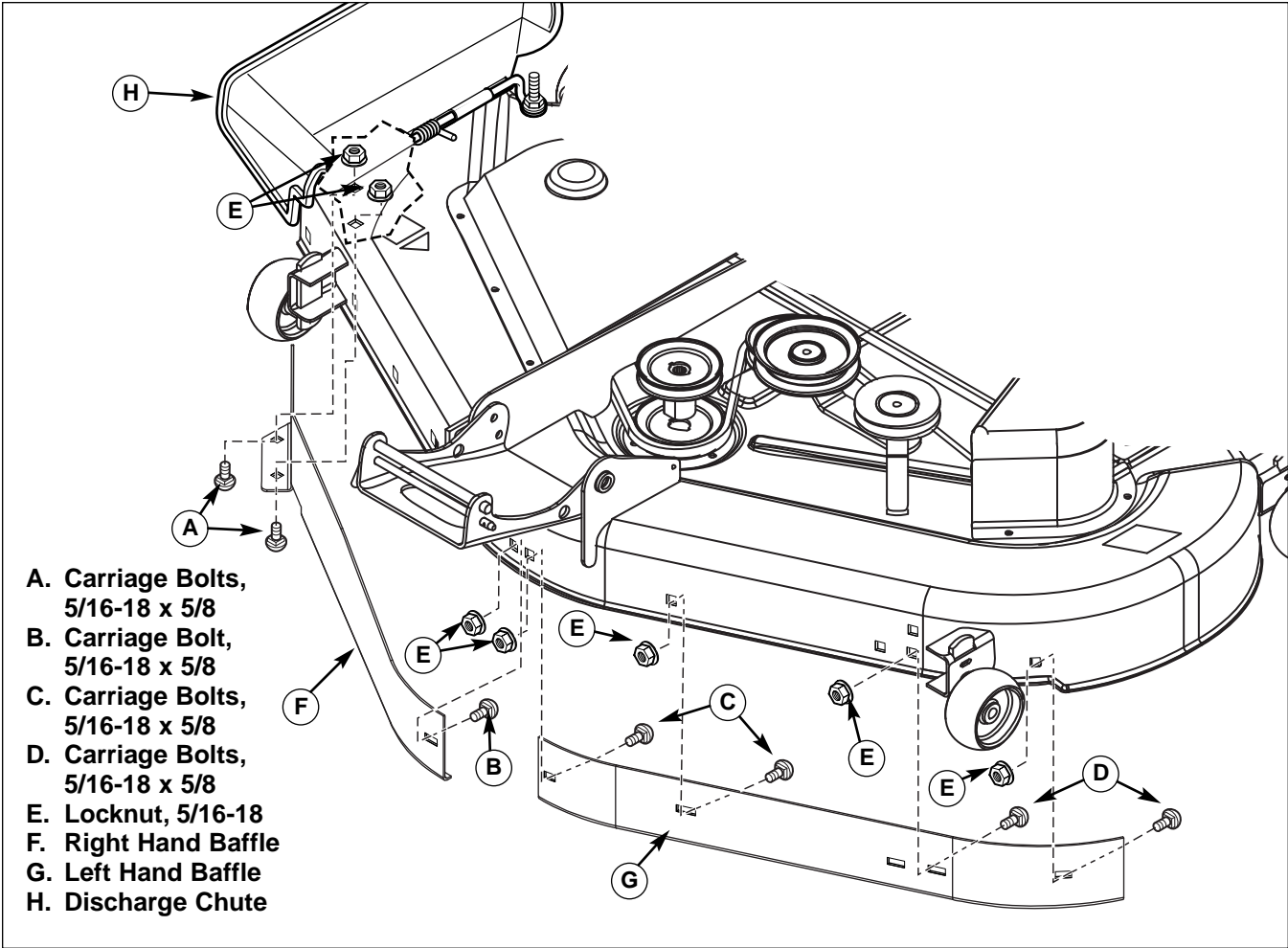

Figure 6. Install Baffles

Install Components

INSTALL MOUNTING PLATE

1. Install mounting plate (A, Figure 7) to mower deck as shown. Secure with 5/16-18 x 5/8 carriage bolts (C) and 5/16-18 locknuts (A).

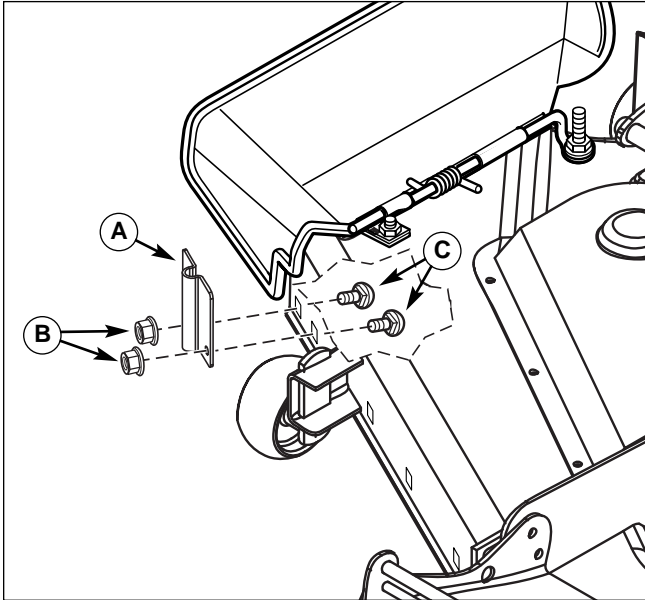

Figure 7. Install Mounting Plate

- A. Mounting Plate
- B. Locknuts, 5/16-18
- C. Carriage Bolts, 5/16-18 x 5/8

INSTALL LOWER CHUTE ROD AND PIN TO BOOT

1. Insert the head of pin (A, Figure 8) through front hole of lower chute (D). Secure with 1/4-20 x 5/8 carriage bolt (B) and 1/4-20 lock nut (C) as shown.
2. Install the rod (H) to lower chute (D) using 5/16-18 x 1 cap screw (J) and 5/16-18 locknut (G) for front holes. Use 5/16-18 x 1-1/4 cap screw (I) and 5/16-18 locknut (G) as shown. Tighten hardware.
3. Install the rubber strap (F) onto cap screw (I) securing with 5/16-18 locknut as shown.

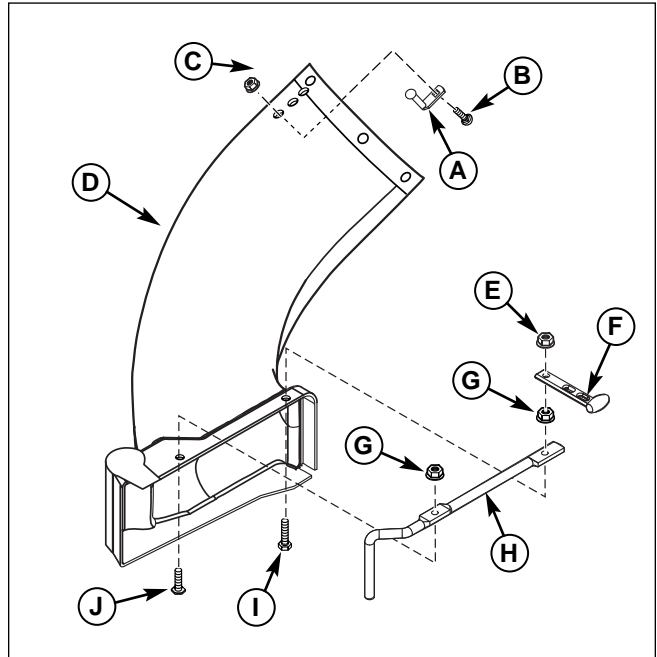

Figure 8. Install Lower Chute and Pin to Boot

- A. Pin, Latch
- B. Carriage Bolt, 1/4-20 x 5/8
- C. Locknut, 1/4-20
- D. Lower Chute
- E. Locknut, Center Lock, 5/16-18
- F. Strap, Rubber
- G. Locknuts, Whiz Lock, 5/16-18
- H. Rod, Boot Mount
- I. Capscrew, Hex Head, 5/16-18 x 1-1/4
- J. Capscrew, Hex Head, Thin, 5/16-18 x 1

INSTALL HANDLE TO TUBE

1. Install handle (A, Figure 9) using 1/4-20 x 1/2 screw and 1/4-20 locknut (B) for rear hole. Use 1/4-20 x 1 screw (D) as shown. Tighten hardware.
2. Install strap (E) to screw (D) securing with 1/4-20 locknut (F).

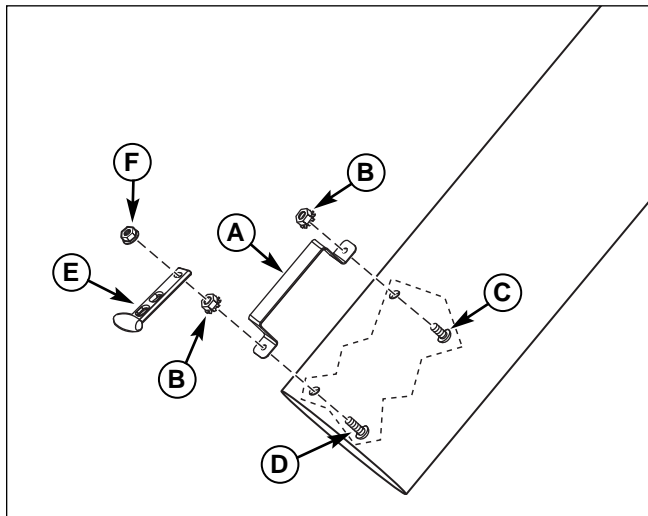

Figure 9. Install Handle to Tube

- A. Handle
- B. Locknuts, KEPS, 1/4-20
- C. Screw, Slotted, 1/4-20 x 1/2
- D. Screw, Slotted, 1/4-20 x 1
- E. Strap, Rubber
- F. Locknut, Center Lock, 1/4-20

INSTALL BAG AND COVER SUPPORT

1. Install the bag and cover support (B, Figure 10) to upright support (A) using reinforcement plate (C) and 3/8-16 x 1 capscrews (D) and 3/8-16 locknuts (E) as shown.

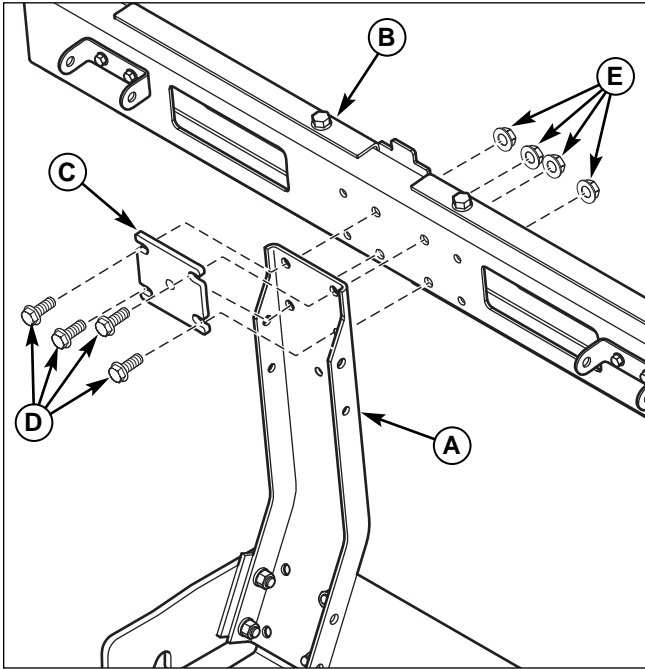

Figure 10. Install Bag and Cover Support

- A. Upright Support
- B. Bag and cover Support
- C. Reinforcement Plate
- D. Capscrews, 3/8-16 x 1
- E. Locknuts, 3/8-16

INSTALL COVER ASSEMBLY

1. Attach cover assembly (B, Figure 12) to bag support bracket (A) using hinge pivots (E). Secure cover using cover hinge pins (C) and hair pins (D) as shown.

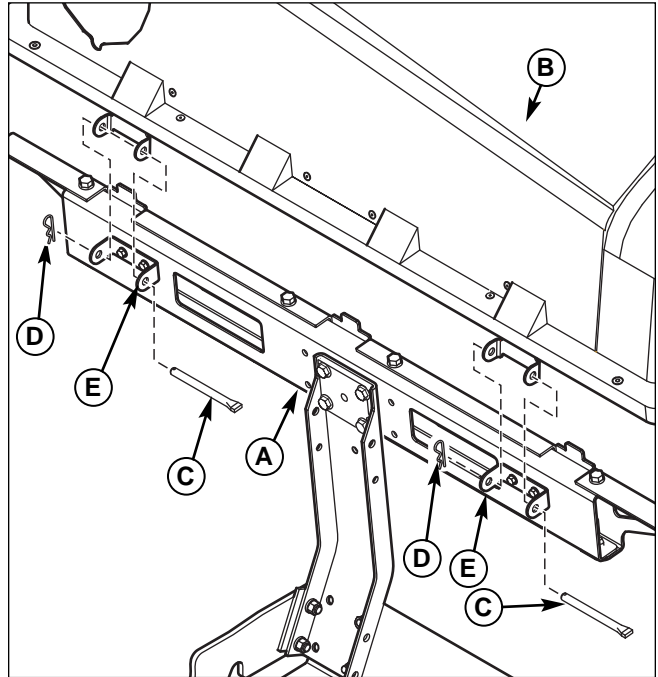

Figure 12. Install Cover Assembly

- A. Bag Support Bracket
- B. Cover Assembly
- C. Cover Hinge Pins
- D. Hair Pins
- E. Hinge Pivots

INSTALL HITCH AND UPRIGHT SUPPORT ASSEMBLY

1. Attach hitch and upright support assembly (A, Figure 11) to frame spacers (B) as shown.

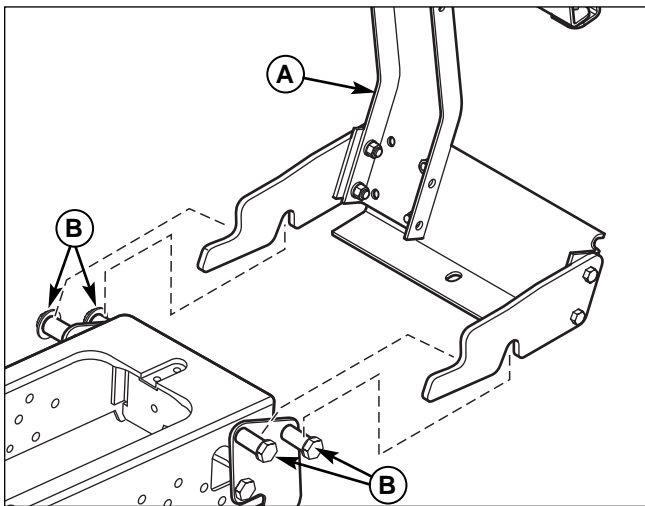

Figure 11. Attach Hitch and Upright Support

- A. Hitch and Upright Support Assembly
- B. Frame spacers

INSTALL COLLECTOR BAGS

1. Raise the cover (A, Figure 13).
2. Attach collector bags (B) using grass bag hanger (C) to bag hanger post (D).

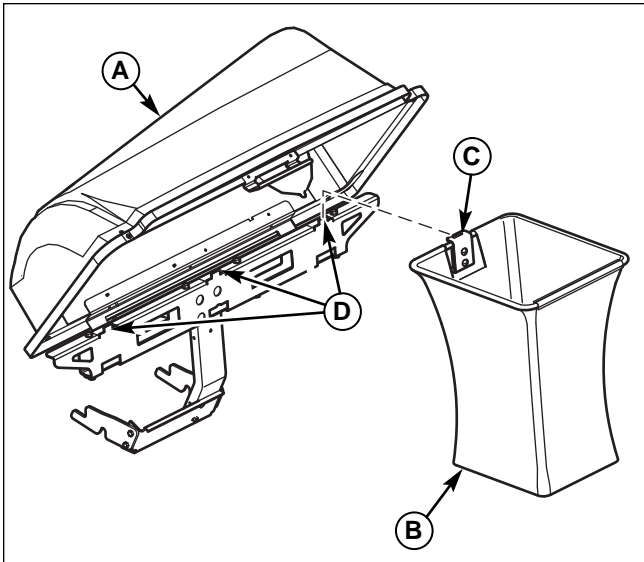

Figure 13. Install Collector Bags

- A. Cover
- B. Collector Bag
- C. Grass Bag Hanger
- D. Bag Hanger Posts

INSTALL LOWER DISCHARGE CHUTE

1. Lift discharge deflector up (D, Figure 14).
2. Insert lower chute rod (A) into mounting plate (B).
3. Pull rubber strap (C) and secure by placing hole closest to knob in strap completely over locknut (E).

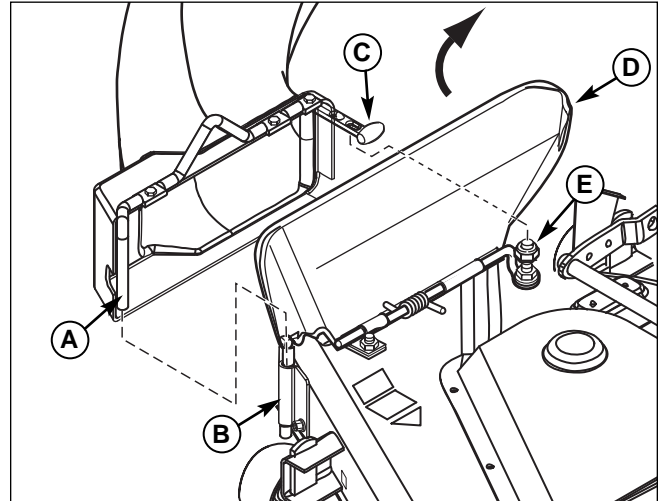

Figure 14. Install Lower Discharge Chute

- A. Lower Chute Rod
- B. Mounting Plate
- C. Rubber Strap
- D. Discharge Deflector
- E. Locknut

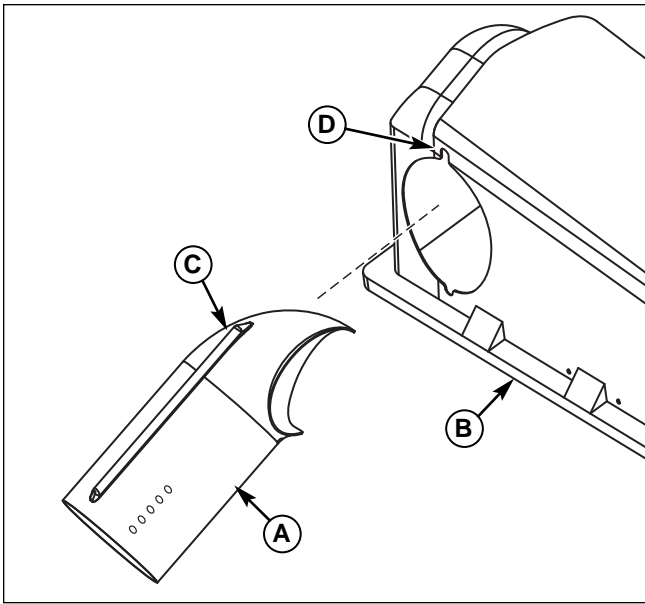

Figure 15. Install Upper Tube to Cover
A. Upper Tube
B. Cover
C. Ridge, Upper Tube
D. Ridge Cutout

INSTALLING UPPER & MIDDLE TUBES

1. Slide the upper tube (E, Figure 15) into cover (B) aligning ridge (C) with cutout (D) as shown.
2. See Figure 16 for correct hole location and secure the upper tube (E) to middle tube using screw (F).
2. Slide middle tube (D, Figure 16) into upper tube (E).
3. Slide middle tube (D) over boot (A). Pull strap (B) and place hole completely over pin (C).

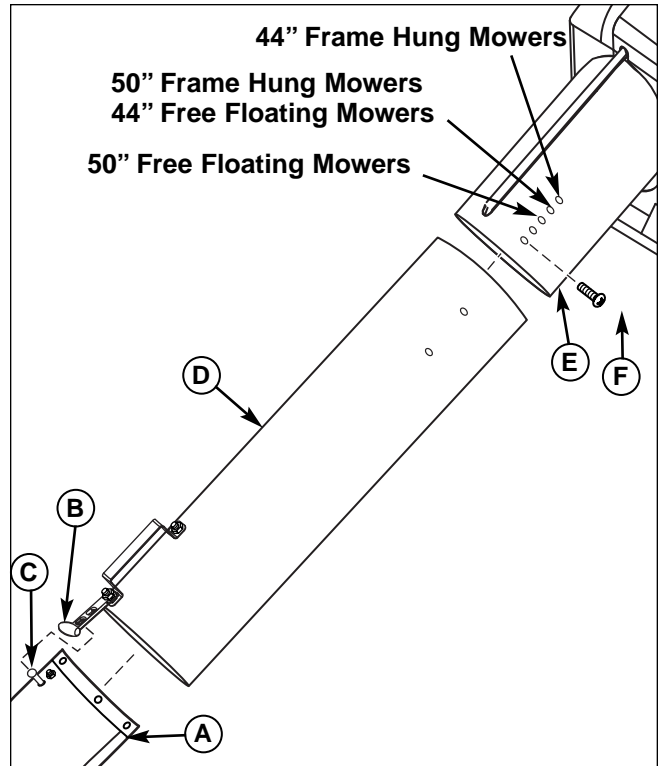
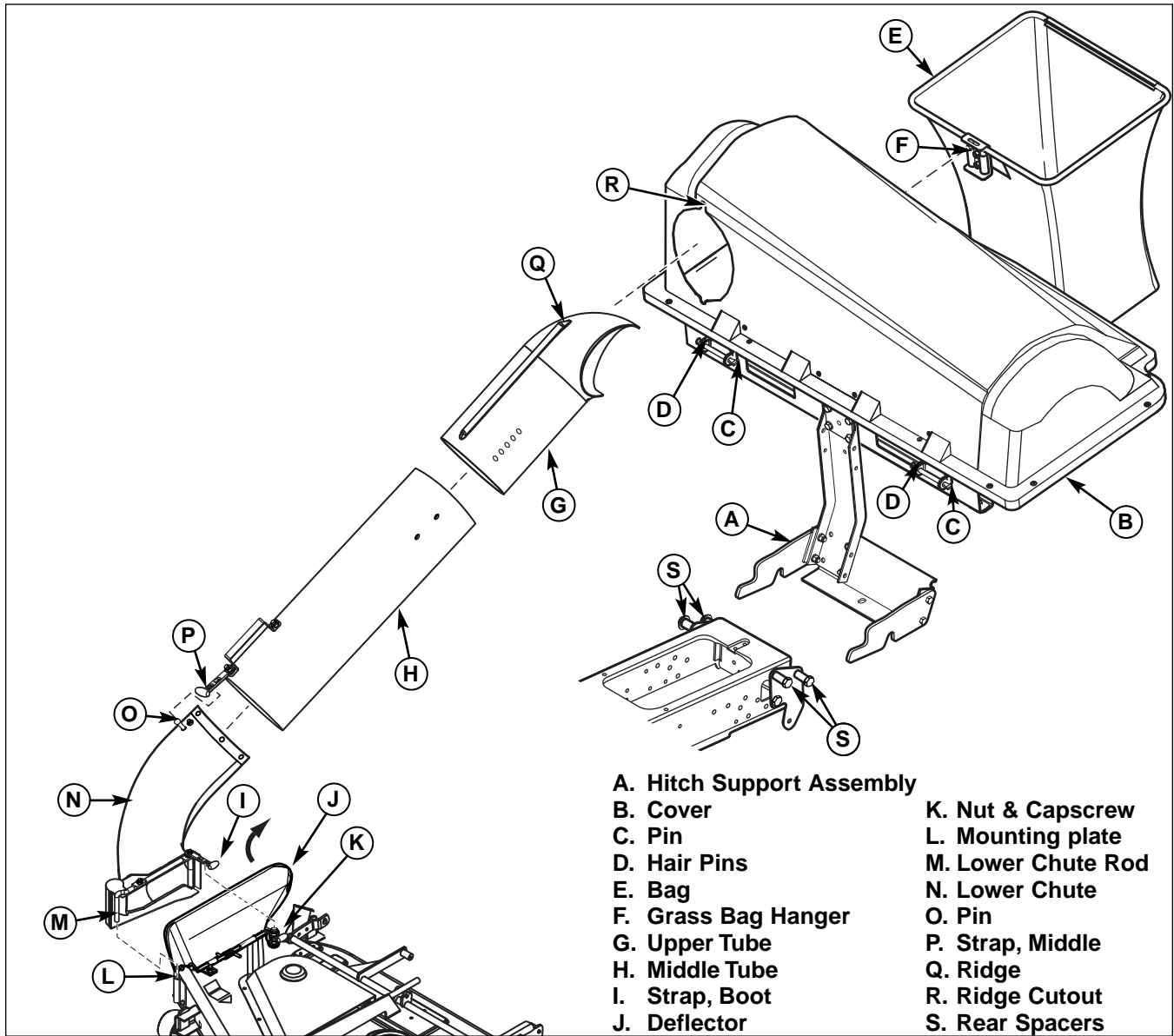

Figure 16. Install Middle Tube
A. Lower Chute
B. Strap, Rubber
C. Pin
D. Middle Tube
E. Upper Tube
F. Screw, 1/4 x 3/4

Normal Removal & Installation

Normal Removal & Installation



- A. Hitch Support Assembly
- B. Cover
- C. Pin
- D. Hair Pins
- E. Bag
- F. Grass Bag Hanger
- G. Upper Tube
- H. Middle Tube
- I. Strap, Boot
- J. Deflector
- K. Nut & Capscrew
- L. Mounting plate
- M. Lower Chute Rod
- N. Lower Chute
- O. Pin
- P. Strap, Middle
- Q. Ridge
- R. Ridge Cutout
- S. Rear Spacers

Figure 17. Normal Installation & Removal

Normal Removal & Installation

Collector Installation

Note: See previous pages for more detailed installation and operation instructions if necessary.

1. Mount the hitch support assembly (A, Figure 17) onto rear tractor frame spacers (S).
2. Attach cover (B) to support assembly using pins (C) and hair pins (D).
3. Pivot cover (B) up. Install bags (E) by attaching grass bag hanger (F) to support assembly (A).

4. Lift discharge deflector (J) up. Insert lower chute rod (M) into mounting plate (L). Pull strap (I) and secure by placing hole closest to knob in strap completely over locknut and capscrew (K).
5. Slide the upper tube (G) into cover (B) aligning ridge (Q) with cutout (R) as shown.
6. Slide middle tube (H) into upper tube (G). Slide middle tube (H) over lower chute (N). Pull strap (P) and place hole completely over pin (O).

Collector Removal

WARNING

OPERATION WITHOUT BAGGER

For operation without bagger, the mower deflector MUST be properly installed in the down position and retained by the spring latch.

1. Unhook strap (P, Figure 17) from pin (O). Slide middle tube (H) into upper tube (G) and remove middle tube (H). Remove upper tube (G) from cover (B).
2. Lift up cover (B) remove and empty bags (E).
3. Unhook strap (I) from locknut and capscrew (K). Remove lower chute (N) from mounting plate (L). See that the discharge deflector (J) returns to the DOWN position.
4. Remove hair pin (D) and pins (C) then remove cover (B).

Note: To prevent loss of parts, reinstall pins (C) and hair pins (D) in support assembly hinge pivots (E, Figure 17).

5. Remove hitch support assembly (A) from rear frame spacers (S).



MANUFACTURING, INC.
500 N Spring Street / PO Box 997
Port Washington, WI 53074-0997

www.SimplicityMfg.com



500 N Spring Street / PO Box 997
Port Washington, WI 53074-0997

www.MasseyLawn.com



PRODUCTS
535 Macon Street
McDonough, GA 30253

www.Snapper.com



500 N Spring Street / PO Box 997
Port Washington, WI 53074-0997

AGCOLawn.com

Briggs & Stratton Yard Power Products Group
Copyright © 2007 Briggs & Stratton Corporation
Milwaukee, WI USA. All Rights Reserved